

Technical Information

Addenda - 54" Baked Goods Station - Bakery Of The Future

Structural Concepts®

DELIVERING FRESH. ALWAYS.™

DIMENSIONS / SHIPPING				
Model	L"	L1"	L2"	Est Wt (lbs)
SHC5454.7981	54.000	N/A	0.000	N/A

ELECTRICAL															
Model	System Circuit Volts			Ph	Frq	Rated Load Amps	Min Cir Amps	Max OCP Amps	Watts	Wires	NEMA Plug	Amps Lights	Amps Fans	Amps Anti-Sweats	Amps Misc/Refrig/Heat
SHC5454.7981	N/A	N/A	N/A	N/A	N/A	N/A	N/A	N/A	N/A	N/A	N/A	N/A	N/A	N/A	N/A

REFRIGERATION														
Model	Zone	Section	System	Env't	REMOTE REFRIGERATION					GLYCOL / R744 REFRIGERATION				
					SST (°F)	Conv. Rack BTUH	Para. Rack BTUH	Defrost Interval (Hrs)	Defrost Duration	Total GPM	Pressure Drop (psi)	Concent (%)	Liquid Temp (°F)	
SHC5454.7981	All	Ambient	None-N/A	Type I	N/A	N/A	N/A	N/A	N/A	N/A	N/A	N/A	N/A	N/A

INTENDED ENVIRONMENT	
Type I - Designed to operate in ambient conditions of 75°F with 55% relative humidity unless noted otherwise under Env't above.	

IMPORTANT NOTES
1) Units are supplied with levelers which must be adjusted during installation to ensure the unit is level and plumb.

WARMEST AVERAGE PRODUCT TEMP & INTENDED USE OF ZONES		
Zone	Temp (°F)	Intended Use
1	Ambient	Packaged non-refrigerated products

REGULATORY	
None	



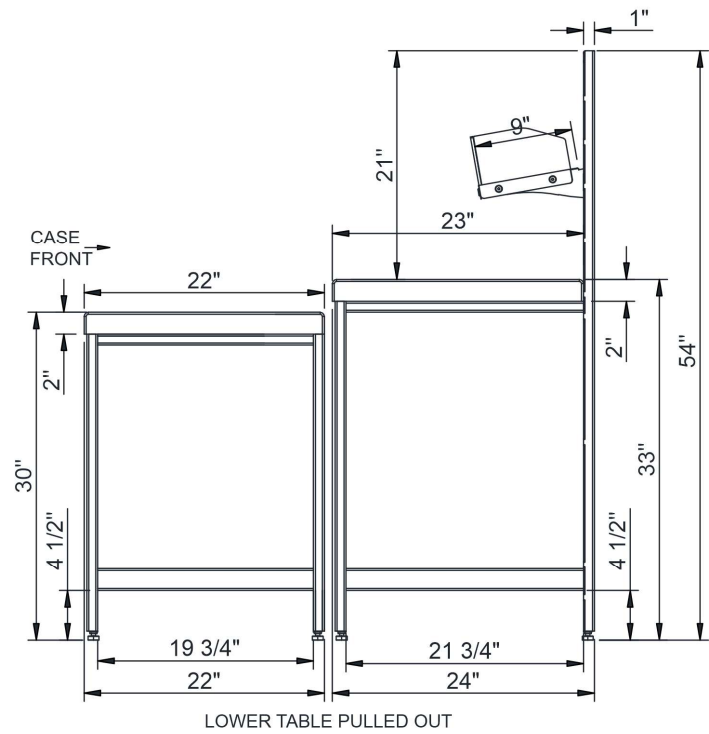
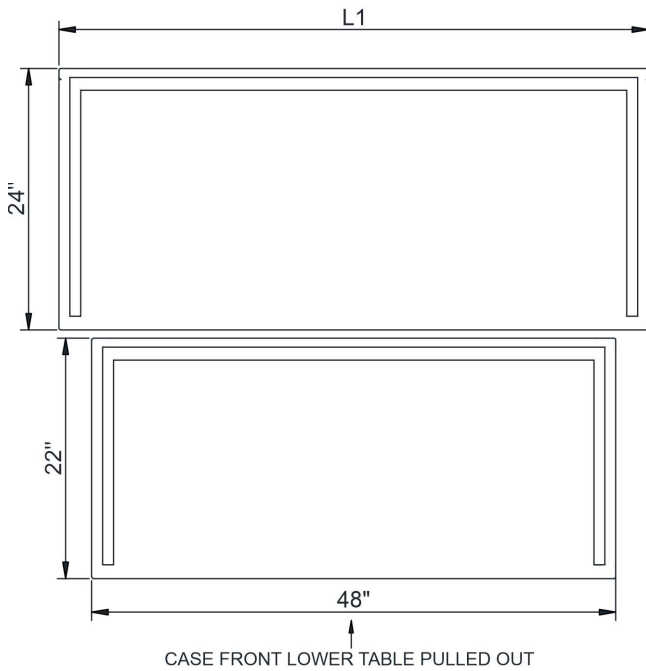
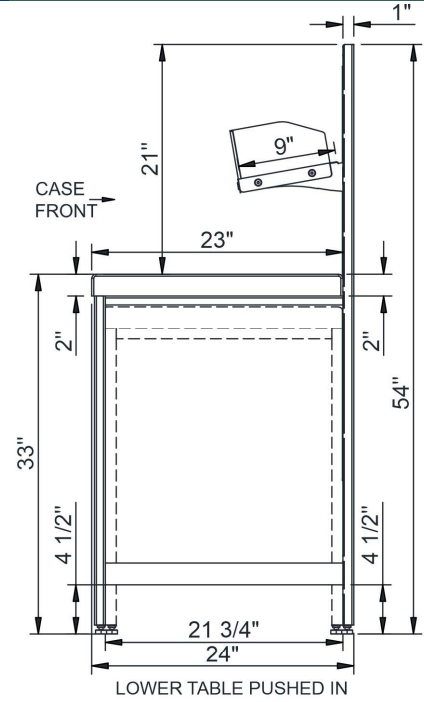
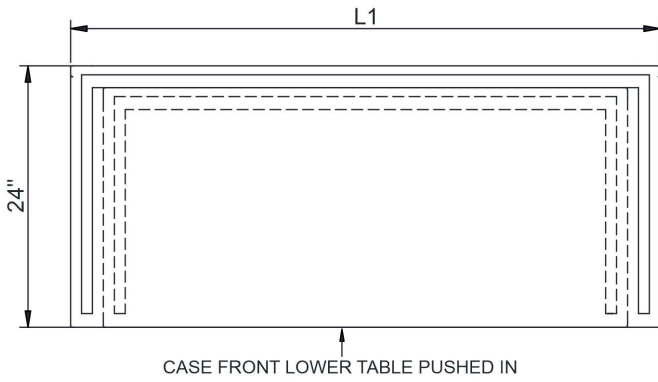

NOTE: ALL DIMENSIONS APPROXIMATE

-  ELECTRICAL JUNCTION BOX (SUPPLIED WITH 6" LEADS OR POWER CORD).
-  LOCATION OF DRAIN TUBE FOR REMOTE REF. ONLY (SUPPLIED WITH 3/4" OR 1 1/2" PVC TUBE).

-  REFRIGERATION LINE CONNECTION.
-  REMOTE FLOOR SINK & UTILITIES ACCESS AREA.

-  SELF-CONTAINED CASE SERVICE ACCESS AREA.
-  DRY CASE SERVICE ACCESS AREA.