

Technical Information

Reveal® - Heated Self-Service Case

Structural Concepts®

DELIVERING FRESH. ALWAYS.™

DIMENSIONS / SHIPPING				
Model	L"	L1"	L2"	Est Wt (lbs)
NR3647HSSV	N/A	35.750	0.000	N/A
NR4847HSSV	N/A	47.750	0.000	N/A

ELECTRICAL															
Model	System Circuit Volts			Ph	Frq	Rated Load Amps	Min Cir Amps	Max OCP Amps	Watts	Wires	NEMA Plug	Amps Lights	Amps Fans	Amps Anti-Sweats	Amps Misc/Refrig/Heat
NR3647HSSV	Heat (N/A)	Circuit #1	208-240	1	60	18.25	30	30	3,604	2+G	6-30P or L6-30P	0.36	0.39	N/A	17.50
NR4847HSSV	Heat (N/A)	Circuit #1	208-240	1	60	24.37	40	40	4,838	2+G	6-30P or L6-30P	0.36	0.46	N/A	23.55

REFRIGERATION													
Model	Zone	Section	System	Envt	REMOTE REFRIGERATION					GLYCOL / R744 REFRIGERATION			
					SST (°F)	Conv. Rack BTUH	Para. Rack BTUH	Defrost Interval (Hrs)	Defrost Duration	Total GPM	Pressure Drop (psi)	Concent (%)	Liquid Temp (°F)

INTENDED ENVIRONMENT		
Type I - Designed to operate in ambient conditions of 75°F with 55% relative humidity unless noted otherwise under Envt above.		
WARMEST AVERAGE PRODUCT TEMP & INTENDED USE OF ZONES		
Zone	Temp (°F)	Intended Use
1	160	Packaged / unpackaged heated products

IMPORTANT NOTES
1) ELECTRICAL NOTE: If GFCI is required, a GFCI breaker MUST be used in lieu of a GFCI receptacle
2) Glass warranty only applicable to first point of delivery.

REGULATORY	
None	



Technical Information



Reveal® - Heated Self-Service Case

Structural Concepts®

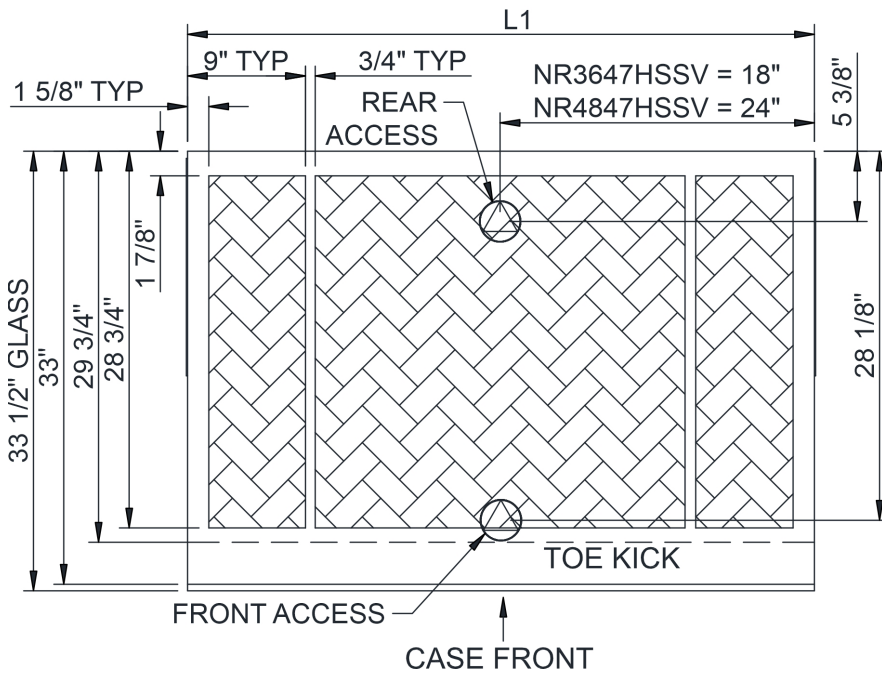
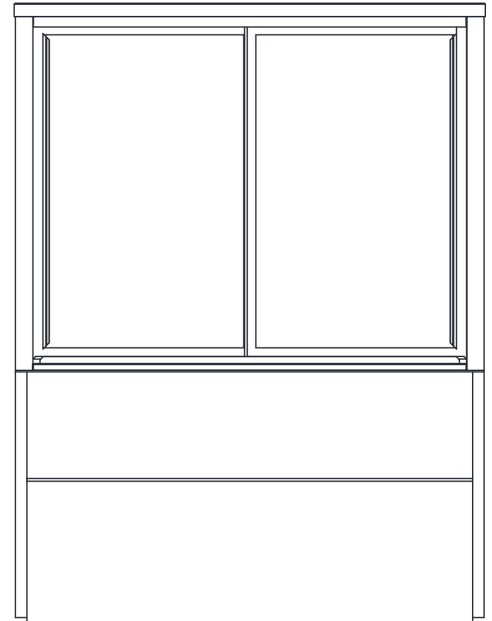
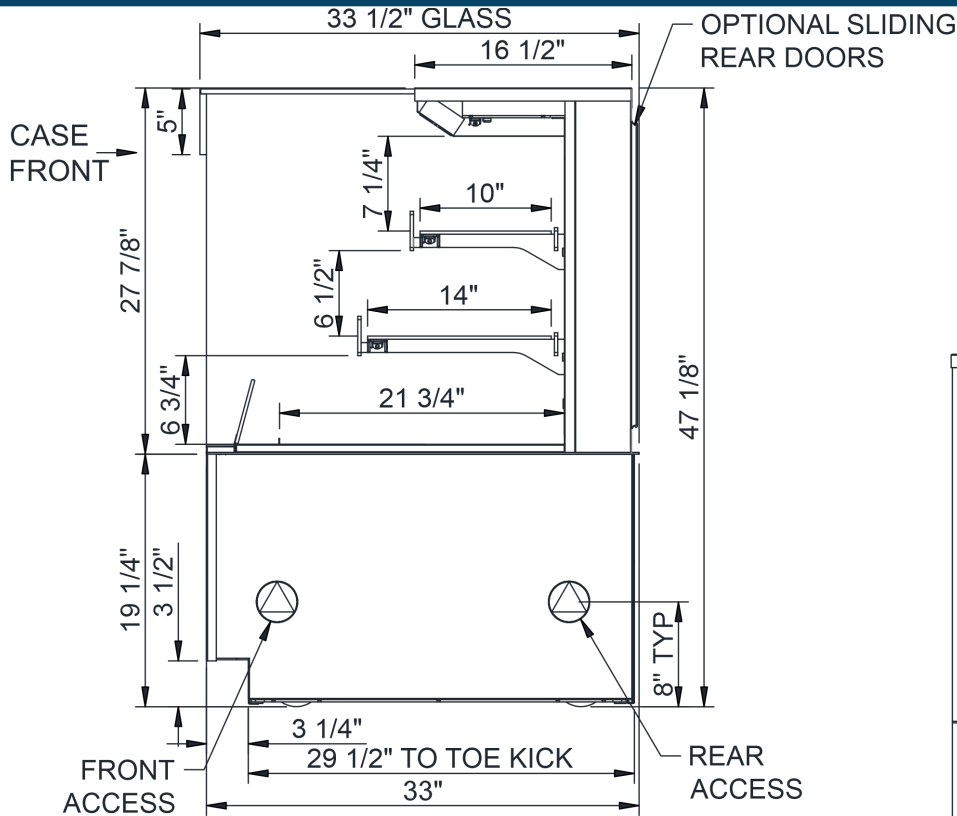
DELIVERING FRESH. ALWAYS.™



NOTE: ALL DIMENSIONS APPROXIMATE

-  ELECTRICAL JUNCTION BOX (SUPPLIED WITH 6" LEADS OR POWER CORD).
-  LOCATION OF DRAIN TUBE FOR REMOTE REF. ONLY (SUPPLIED WITH 3/4" OR 1 1/2" PVC TUBE).

-  REFRIGERATION LINE CONNECTION.
-  REMOTE FLOOR SINK & UTILITIES ACCESS AREA.

-  SELF-CONTAINED CASE SERVICE ACCESS AREA.
-  DRY CASE SERVICE ACCESS AREA.