

Technical Information

Prepared Foods - Chef's Selection High-Capacity Self-Service Case - Remote DX w/ Carel Heos Controller

DIMENSIONS / SHIPPING				
Model	L"	L1"	L2"	Est Wt (lbs)
GHSS656R.5718.8114	73.000	75.250	3.500	N/A

ELECTRICAL																
Model	System Circuit Volts				Ph	Frq	Rated Load Amps	Min Cir Amps	Max OCP Amps	Watts	Wires	NEMA Plug	Amps Lights	Amps Fans	Amps Anti-Sweats	Amps Misc/Refrig/Heat
GHSS656R.5718.8114	Remote (DX)	Circuit #1	110-120	1	60	1.92	15	15	158	2+G	Leads Single	0.70	0.93	0.29	N/A	

REFRIGERATION													
Model	Zone	Section	System	Envt	REMOTE REFRIGERATION					GLYCOL / R744 REFRIGERATION			
					SST (°F)	Conv. Rack BTUH	Para. Rack BTUH	Defrost Interval (Hrs)	Defrost Duration	Total GPM	Pressure Drop (psi)	Concent (%)	Liquid Temp (°F)
GHSS656R.5718.8114	All	Refrigerator	Remote-DX	Type I	20	7,085	6,560	4.00	25.00	N/A	N/A	N/A	N/A

INTENDED ENVIRONMENT		
WARMEST AVERAGE PRODUCT TEMP & INTENDED USE OF ZONES		
Zone	Temp (°F)	Intended Use
1	40	Packaged refrigerated products

IMPORTANT NOTES
1) Units must be shimmed during installation to ensure the unit is level and plumb.

REGULATORY	
All Models	Accordance with AHRI Std 1200 ETL Listed to UL 471 ETL Listed to CAN/CSA 22.2 No. 120 ETL Sanitation to NSF/ANSI 7



In Accordance with
AHRI Std 1200

Prepared Foods - Chef's Selection High-Capacity Self-Service Case - Remote DX w/ Carel Heos Controller

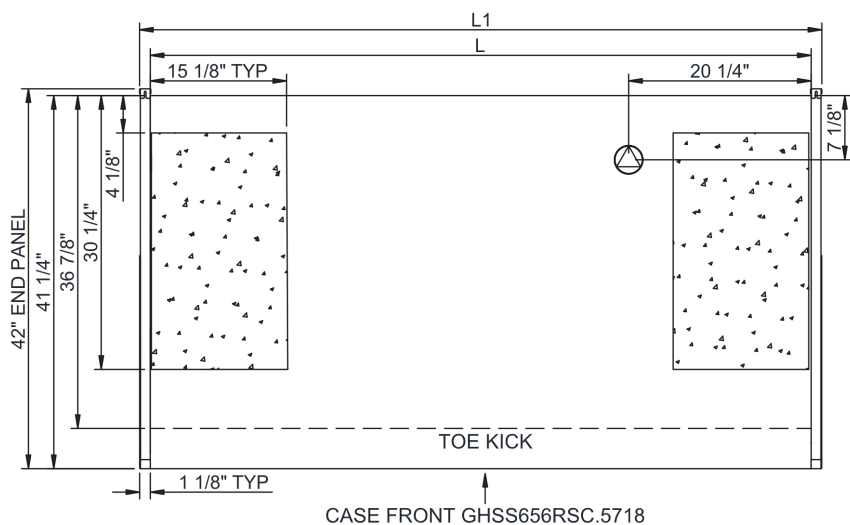
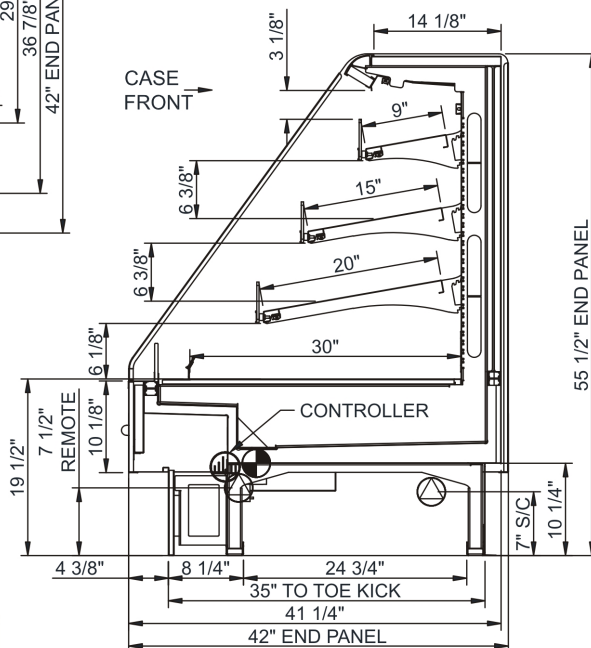
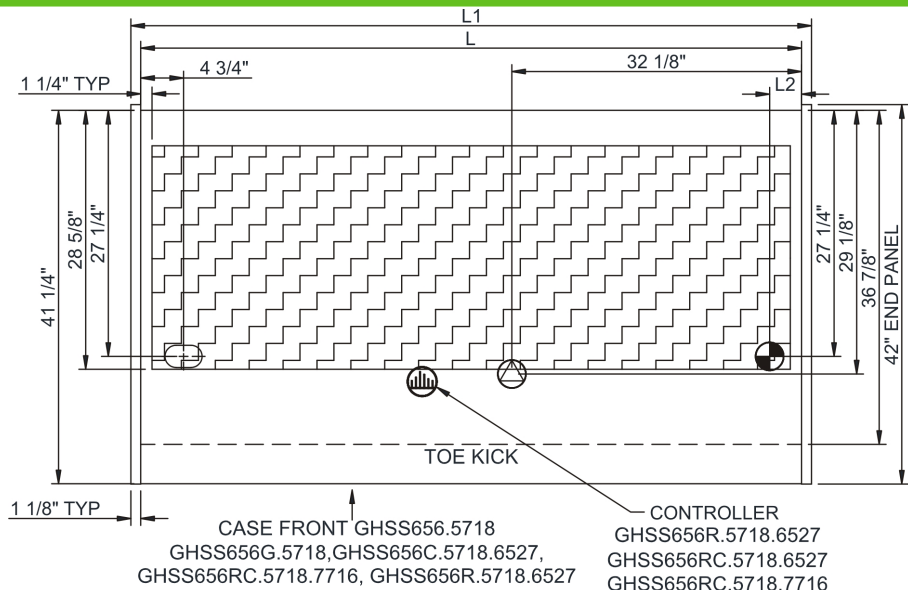

NOTE: ALL DIMENSIONS APPROXIMATE

-  ELECTRICAL JUNCTION BOX (SUPPLIED WITH 6" LEADS OR POWER CORD).
-  REFRIGERATION LINE CONNECTION.
-  SELF-CONTAINED CASE SERVICE ACCESS AREA.
-  LOCATION OF DRAIN TUBE FOR REMOTE REF. ONLY (SUPPLIED WITH 3/4" OR 1 1/2" PVC TUBE).
-  REMOTE FLOOR SINK & UTILITIES ACCESS AREA.
-  DRY CASE SERVICE ACCESS AREA.