

Prepared Foods - Chef's Selection High-Capacity Self-Service Case - Remote DX w/ Controller

Models

GHSS656R.5718.6527



Features	Standard	Options
EXTERIOR COLOR	<input type="checkbox"/> Laminated (Xanadu)	
EXTRUSION COLOR	<input type="checkbox"/> Black	
INTERIOR COLOR	<input type="checkbox"/> Black	
BUMPER	<input type="checkbox"/> Bumper on front	<input type="checkbox"/> Bumper on end
CASE PROFILE	<input type="checkbox"/> Flat angled	
END PANELS	<input type="checkbox"/> None (specify per line-up)	<input type="checkbox"/> Case to case full end <input type="checkbox"/> Full with mirror
TOP BOARD	<input type="checkbox"/> Stainless steel	
UPPER REAR	<input type="checkbox"/> Solid back panel	
PRICE TAG MOLDING	<input type="checkbox"/> Price tag molding	
SHELVING	<input type="checkbox"/> (3) Lighted solid shelves	
LIGHTING UPPER	<input type="checkbox"/> LED top light(s)	
ELECTRICAL CONNECT	<input type="checkbox"/> Leads	
REFRIGERATION	<input type="checkbox"/> Remote DX refrigeration w/ controller	

Applications

- Self-Service multi-shelf refrigerated merchandiser for deli and bakery items.

Prepared Foods Chef's Selection High-Capacity Self-Service Case - Remote DX w/ Controller

Model	L x D x H (Lengths do not include 1-1/8" end panels)
GHSS656R.5718.6527	73"L x 42"D x 55-1/2"H

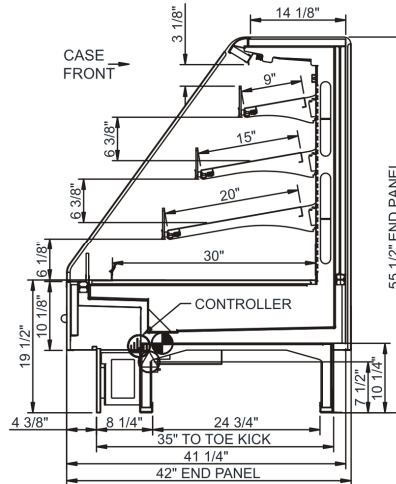

IMPORTANT NOTES:

1) Units must be shimmed during installation to ensure the unit is level and plumb.



WARNING:

This product can expose you to chemicals, including Urethane (Ethyl Carbamate), which are known to the state of California to cause cancer and birth defects or other reproductive harm. For more information go to www.P65Warnings.ca.gov.

INTENDED ENVIRONMENT

Designed to operate in ambient conditions of 75°F with 55% relative humidity.

WARMEST AVG PRODUCT TEMP

Zone	Temp (°F)
1	40

INTENDED USE OF DISPLAY AREAS

Zone	Intended Use
1	Packaged refrigerated products

Prepared Foods - Chef's Selection High-Capacity Self-Service Case - Remote DX w/ Controller

DIMENSIONS / SHIPPING				
Model	L"	L1"	L2"	Est Wt (lbs)
GHSS656R.5718.6527	73.000	75.250	3.500	N/A

ELECTRICAL																
Model	System Circuit Volts				Ph	Frq	Rated Load Amps	Min Cir Amps	Max OCP Amps	Watts	Wires	NEMA Plug	Amps Lights	Amps Fans	Amps Anti-Sweats	Amps Misc/Refrig/Heat
GHSS656R.5718.6527	Remote(DX)	Circuit #1	110-120	1	60	1.89	15	15	115	2+G	Leads Single	0.70	0.90	0.29	N/A	

REFRIGERATION													
Model	Zone	Section	System	Envt	REMOTE REFRIGERATION					GLYCOL / R744 REFRIGERATION			
					SST (°F)	Conv. Rack BTUH	Para. Rack BTUH	Defrost Interval (Hrs)	Defrost Duration (Mins)	Total GPM	Pressure Drop (psi)	Concent (%)	Liquid Temp (°F)
GHSS656R.5718.6527	All	Refrigerator	Remote-DX	Type I	20	7,085	6,560	4.00	25.00	N/A	N/A	N/A	N/A

INTENDED ENVIRONMENT
 Type I - Designed to operate in ambient conditions of 75°F with 55% relative humidity unless noted otherwise under Envt above.

IMPORTANT NOTES
 1) Units must be shimmed during installation to ensure the unit is level and plumb.

WARMEST AVERAGE PRODUCT TEMP & INTENDED USE OF ZONES		
Zone	Temp (°F)	Intended Use
1	40	Packaged refrigerated products

REGULATORY	
All Models	Accordance with AHRI Std 1200 ETL Listed to UL 471 ETL Listed to CAN/CSA 22.2 No. 120 ETL Sanitation to NSF 7



In Accordance with
AHRI Std 1200

Prepared Foods - Chef's Selection High-Capacity Self-Service Case - Remote DX w/ Controller

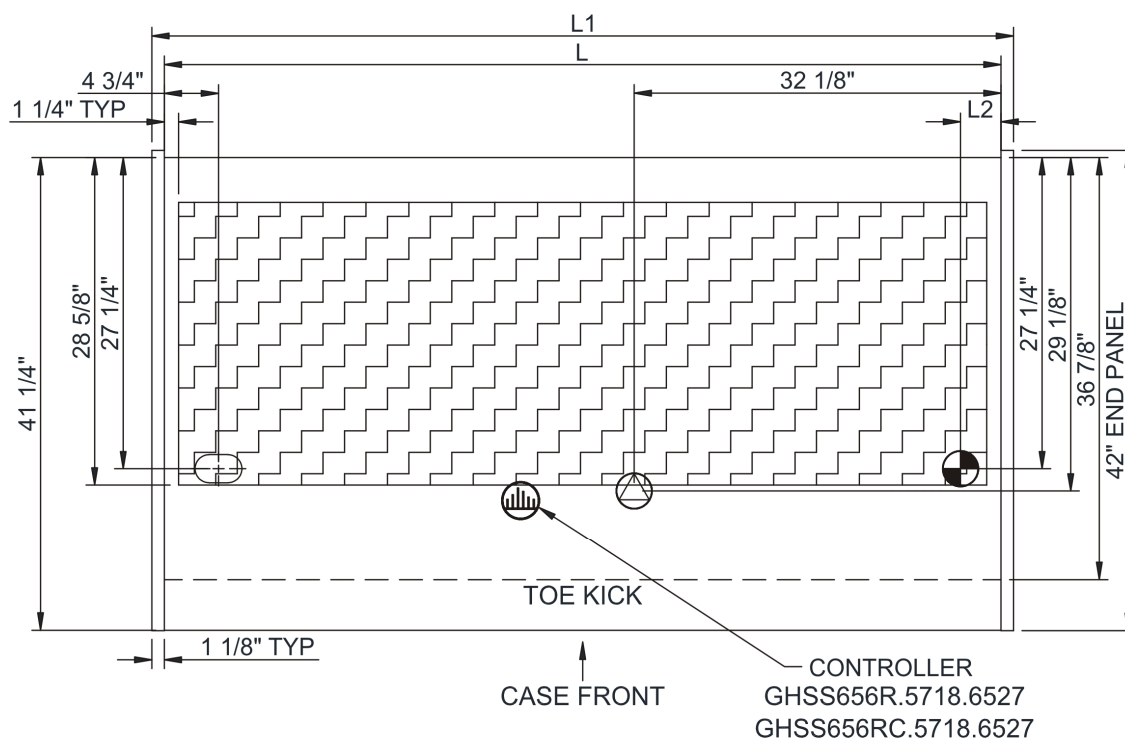
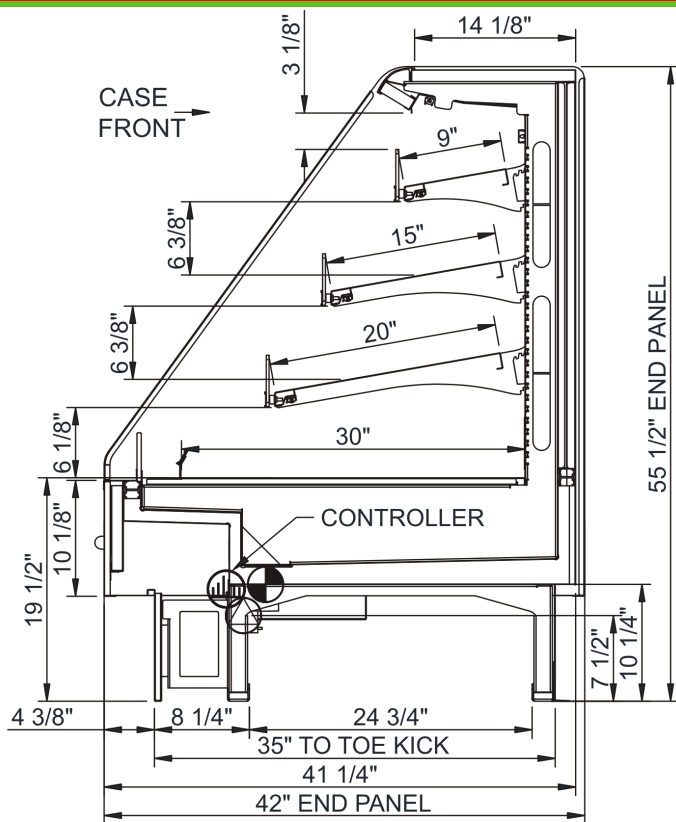

NOTE: ALL DIMENSIONS APPROXIMATE

- ⊗ ELECTRICAL JUNCTION BOX (SUPPLIED WITH 6" LEADS OR POWER CORD).
- ⊕ REFRIGERATION LINE CONNECTION.
- ⊙ LOCATION OF DRAIN TUBE FOR REMOTE REF. ONLY (SUPPLIED WITH 3/4" OR 1 1/2" PVC TUBE).
- ⊞ REMOTE FLOOR SINK & UTILITIES ACCESS AREA.
- ⊠ SELF-CONTAINED CASE SERVICE ACCESS AREA.
- ⊡ DRY CASE SERVICE ACCESS AREA.