

# Technical Information

Fusion - Heated Service Case - 3 Levels - Angled Glass - Inline

Structural Concepts®

DELIVERING FRESH. ALWAYS.™

DIMENSIONS / SHIPPING				
Model	L"	L1"	L2"	Est Wt (lbs)
GHS355H.5718A	39.500	41.250	0.000	N/A

ELECTRICAL															
Model	System Circuit Volts			Ph	Frq	Rated Load Amps	Min Cir Amps	Max OCP Amps	Watts	Wires	NEMA Plug	Amps Lights	Amps Fans	Amps Anti-Sweats	Amps Misc/Refrig/Heat
GHS355H.5718A	Heat (N/A)	Circuit #1	110-120	1	60	7.25	15	15	884	2+G	Leads Single	0.58	N/A	N/A	6.67
	Heat (N/A)	Circuit #1	110-120	1	60	7.37	15	15	818	2+G	Leads Single	0.70	N/A	N/A	6.67

REFRIGERATION													
Model	Zone	Section	System	Envt	REMOTE REFRIGERATION					GLYCOL / R744 REFRIGERATION			
					SST (°F)	Conv. Rack BTUH	Para. Rack BTUH	Defrost Interval (Hrs)	Defrost Duration	Total GPM	Pressure Drop (psi)	Concent (%)	Liquid Temp (°F)

INTENDED ENVIRONMENT
Type I - Designed to operate in ambient conditions of 75°F with 55% relative humidity unless noted otherwise under Envt above.

IMPORTANT NOTES
1) ELECTRICAL NOTE: If GFCI is required, a GFCI breaker MUST be used in lieu of a GFCI receptacle.

WARMEST AVERAGE PRODUCT TEMP & INTENDED USE OF ZONES		
Zone	Temp (°F)	Intended Use
1	160	Packaged heated products-Preheated to Warmest Avg Prod Temp.

REGULATORY	
All Models	ETL Listed to UL 197 ETL Listed to CAN/CSA 22.2 No. 109 ETL Sanitation to NSF/ANSI 4



# Technical Information



Fusion - Heated Service Case - 3 Levels - Angled Glass - Inline

Structural Concepts®

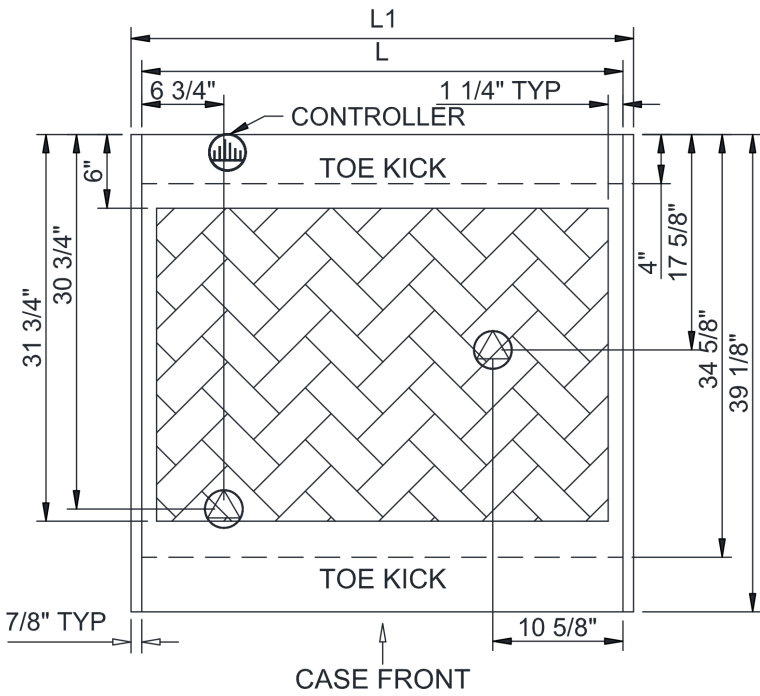
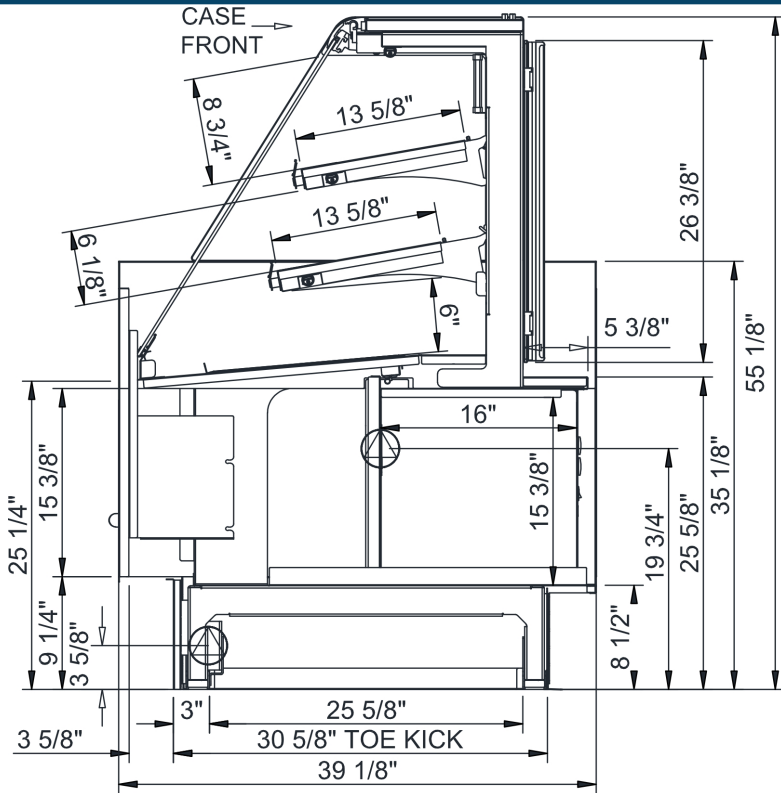
DELIVERING FRESH. ALWAYS.™



NOTE: ALL DIMENSIONS APPROXIMATE

-  ELECTRICAL JUNCTION BOX (SUPPLIED WITH 6" LEADS OR POWER CORD).
-  LOCATION OF DRAIN TUBE FOR REMOTE REF. ONLY (SUPPLIED WITH 3/4" OR 1 1/2" PVC TUBE).

-  REFRIGERATION LINE CONNECTION.
-  REMOTE FLOOR SINK & UTILITIES ACCESS AREA.

-  SELF-CONTAINED CASE SERVICE ACCESS AREA.
-  DRY CASE SERVICE ACCESS AREA.