

• **FB35S-C1E.8110**

45-3/8"L x 39-1/4"D x 60"H

### Included

- Frosted acrylic sneeze guard
- One year parts & labor warranty

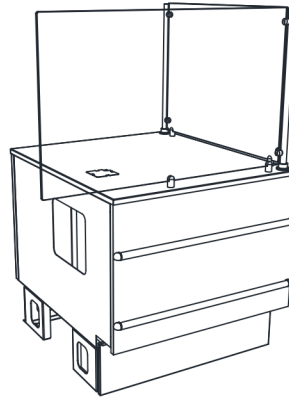

RIGHT HAND CONFIGURATION

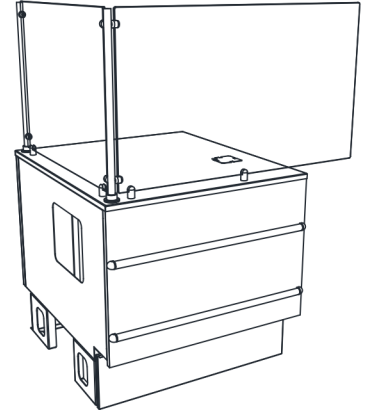

LEFT HAND CONFIGURATION

**FB35S-C1E.8110**

Specify	Standard Features	Additional Options
<b>EXTERIOR COLOR</b>	• Laminated (Xanadu)	• Laminated (Skyline Walnut)
<b>INTERIOR COLOR</b>	• Stainless steel	
<b>BUMPER FRONT</b>	• 1" bumper on front (black)	• 1" bumper on front (Gray)
<b>TOE KICK</b>	• Powder coated Silversan Black	
<b>SNEEZE GUARD</b>	• ADM sneeze guard w/ stainless steel post	

<b>Intended Environment:</b> Type I - Designed to operate in ambient conditions of 75°F with 55% relative humidity unless noted otherwise in system information below.		
<b>Zone</b>	<b>Intended Product To Be Displayed</b>	<b>Warmest Avg Prod Temp ° F</b>
1	Packaged non-refrigerated products	Ambient

**PLAN VIEW**

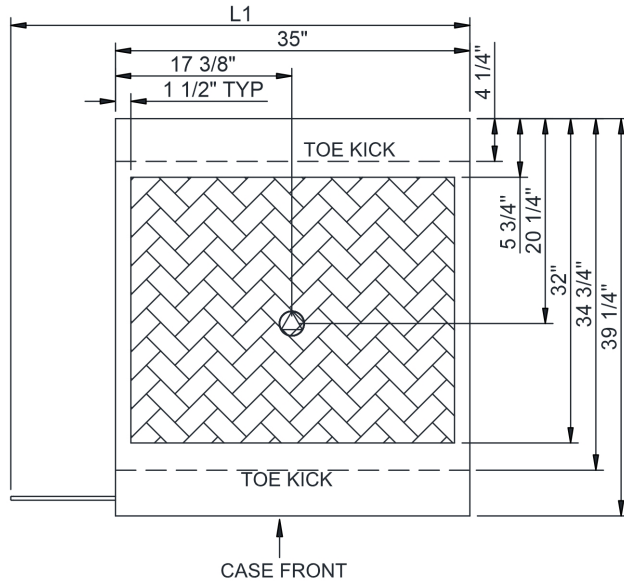

**SIDE VIEW**

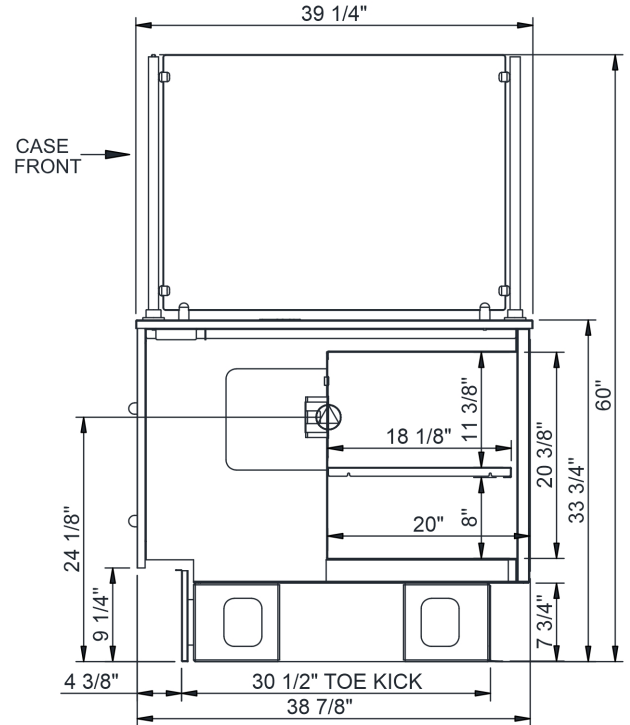

**NOTE: ALL DIMENSIONS APPROXIMATE**

- ELECTRICAL JUNCTION BOX**  
(SUPPLIED WITH 6" LEADS OR POWER CORD).
- LOCATION OF DRAIN TUBE FOR REMOTE REF.**  
ONLY (SUPPLIED WITH 3/4" OR 1 1/2" PVC TUBE).

- REFRIGERATION LINE CONNECTION.**
- REMOTE FLOOR SINK & UTILITIES**  
ACCESS AREA.

- SELF-CONTAINED CASE SERVICE ACCESS AREA.**
- DRY CASE SERVICE ACCESS AREA.**

Model Technical Specifications																
Model	L"	L1"	L2"	System Circuit Volts			Phs	Freq	Amps ***	Watts	Wires	NEMA Plug	SST	Conv. Rack BTUH	Para. Rack BTUH	Est Wt
FB35S-C1E.8110	N/A	45.38	.00	None (N/A)	N/A	N/A	1&3	N/A	0.00	0			N/A	N/A	N/A	N/A

\*\*\* Does not include electric defrost on freezer models.

<b>Regulatory Approvals:</b>	
None	



**Important Notes:**

1) Units must be shimmed during installation to ensure the unit is level and plumb.

**⚠ WARNING:** This product can expose you to chemicals, including Urethane (Ethyl Carbamate), which are known to the State of California to cause cancer and birth defects or other reproductive harm. For more information go to [www.P65Warnings.ca.gov](http://www.P65Warnings.ca.gov).