

# Salad/Sandwich Prep - Point of Service / Interaction Station / Scale Stand

## Models

FB20-C.7989



Features	Standard	Options
<b>EXTERIOR COLOR</b>	<input type="checkbox"/> Laminated (non-premium) Confirm pattern/grain direction	
<b>INTERIOR COLOR</b>	<input type="checkbox"/> Publix matte black	<input type="checkbox"/> Umbra Grey
<b>BASE SUPPORT</b>	<input type="checkbox"/> Rail system for shims	
<b>BUMPER END</b>	<input type="checkbox"/> None	
<b>BUMPER FRONT</b>	<input type="checkbox"/> None	
<b>SCALE STAND</b>	<input type="checkbox"/> Scale stand w/ empty electrical & ethernet box (wiring supplied by others) (requires separate circuit)	
<b>TOE KICK</b>	<input type="checkbox"/> Publix matte black	<input type="checkbox"/> Umbra Grey
<b>TOP</b>	<input type="checkbox"/> Stainless steel	
<b>SHELVING</b>	<input type="checkbox"/> Solid shelves, non-lighted	
<b>ELECTRICAL ACCESS</b>	<input type="checkbox"/> Rear electrical access	

## Applications

- Service non-refrigerated interaction table w/scale stand for deli & bakery items.

# Salad/Sandwich Prep Point of Service / Interaction Station / Scale Stand

Model	L x D x H (Lengths include end panels)
FB20-C.7989	20"L x 39-1/4"D x 33-3/4"H

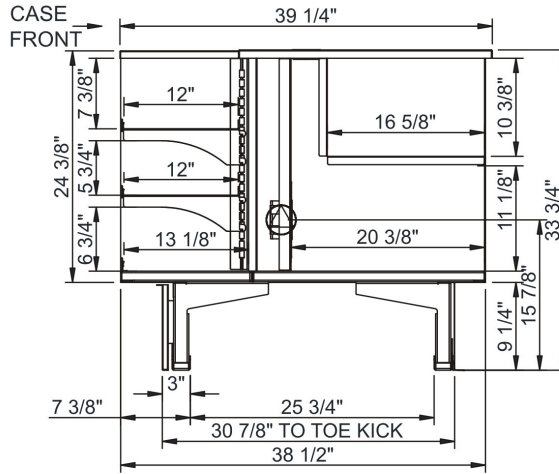

## IMPORTANT NOTES:

### WARNING

This product can expose you to chemicals including Urethane (Ethyl Carbamate), which are known to the State of California to cause cancer and birth defects or other reproductive harm. For more information go to [www.P65Warnings.ca.gov](http://www.P65Warnings.ca.gov).

## INTENDED ENVIRONMENT

Designed to operate in ambient conditions of 75°F with 55% relative humidity.

## WARMEST AVG PRODUCT TEMP

Zone	Temp (°F)
1	

## INTENDED USE OF DISPLAY AREAS

Zone	Intended Use

For more information on any of our products or services please visit us on the web at:

[www.structuralconcepts.com](http://www.structuralconcepts.com)

INFORMATION IS SUBJECT TO CHANGE WITHOUT NOTICE. Visit [www.structuralconcepts.com](http://www.structuralconcepts.com) for the most current specs.