

Food Bars - Refrigerated Self-Service Modular Food Bar w/ Lift-up Sneeze Guard - Glycol

Models

DP710RG.7174
DP812RG.7174
DP1016RG.7174

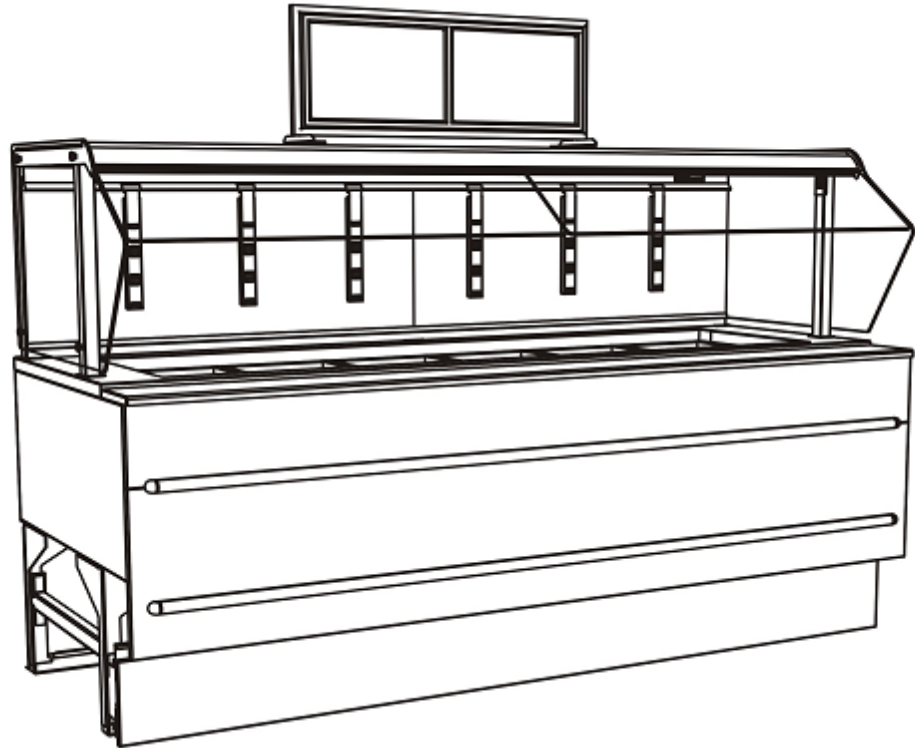

Features	Standard	Options
BASE SUPPORT	<input type="checkbox"/> Rail system for shims	
BUMPER END	<input type="checkbox"/> None	<input type="checkbox"/> 1" bumper (black) (3 rows) <input type="checkbox"/> 1" bumper (Steel Gray) (3 rows)
BUMPER FRONT	<input type="checkbox"/> 1" bumper (black) (2 rows)	<input type="checkbox"/> 1" bumper (Steel Gray) (2 rows)
END PANEL	<input type="checkbox"/> None	<input type="checkbox"/> Full end panel
FRONT TOE KICK	<input type="checkbox"/> Publix matte black	
TRAY RAIL	<input type="checkbox"/> Kilauea Quartz	<input type="checkbox"/> Everest Quartz
UPPER FRONT PANEL	<input type="checkbox"/> Laminated (Xanadu / Carbon Mesh)	<input type="checkbox"/> Laminated (Skyline Walnut) <input type="checkbox"/> Laminated (Xanadu)
UPPER REAR	<input type="checkbox"/> Open upper rear	<input type="checkbox"/> Mirror back panel
INTERIOR	<input type="checkbox"/> Stainless steel	
PANS	<input type="checkbox"/> Condiment pan support rails	
SIGN HOLDER	<input type="checkbox"/> Top sign holder	
SNEEZE GUARD	<input type="checkbox"/> Clear lift-up sneeze guard glass w/ stainless steel posts	
TOP LIGHT	<input type="checkbox"/> LED top light	
ELECTRICAL CONNECT	<input type="checkbox"/> Leads	
REFRIGERATION	<input type="checkbox"/> Remote Glycol refrigeration	

Applications

- One-sided inline cold-well modular w/rear pass through unit for self-service pans.
- Models used in Food Bar Inline & Food Bar Island

Food Bars Refrigerated Self-Service Modular Food Bar w/ Lift-up Sneeze Guard - Glycol

Model	L x D x H (Lengths do not include 3/4" end panels)
DP710RG.7174	79"L x 37"D x 70-1/2"H
DP812RG.7174	92"L x 37"D x 70-1/2"H
DP1016RG.7174*	122"L x 37"D x 70-1/2"H

MODEL	w/ CONTROLLER
DP(L)(X)R.6527	REMOTE DX w/ DIXELL XM670
DP(L)(X)RC.7174.7716	CO2 w/ DANFOSS AK-CC 550A
DP(L)(X)RC.7174.6527	CO2 w/ DIXELL XM670
DP(L)(X)R.7174.7716	REMOTE DX w/ DANFOSS AK-CC 550A
DP(L)(X)R.7174.6527	REMOTE DX w/ DIXELL XM670
MODEL	w/o CONTROLLER
DP(L)(X)R.7174	REMOTE
DP(L)(X)RG.7174	REMOTE GLYCOL

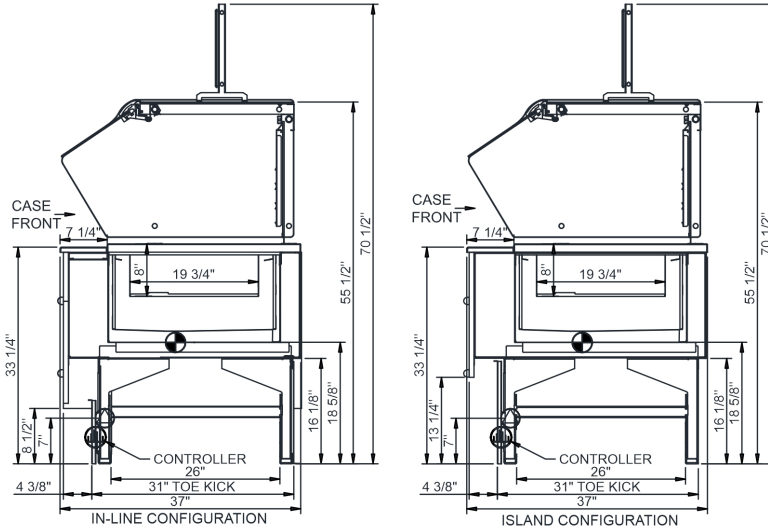

IMPORTANT NOTES:

1) Refrigerated air flow above and below pans.

WARNING

This product can expose you to chemicals including Urethane (Ethyl Carbamate), which are known to the State of California to cause cancer and birth defects or other reproductive harm. For more information go to www.P65Warnings.ca.gov.

INTENDED ENVIRONMENT

Designed to operate in ambient conditions of 75°F with 55% relative humidity.

WARMEST AVG PRODUCT TEMP

Zone	Temp (°F)
1	38

INTENDED USE OF DISPLAY AREAS

Zone	Intended Use
1	Unpackaged refrigerated products

* Additional lead-time required
 INFORMATION IS SUBJECT TO CHANGE WITHOUT NOTICE. Visit www.structuralconcepts.com for the most current specs.

