

# Olive - Refrigerated 5-Pan Olive Unit Inline - Carbon Gray - Lift-up Sneeze Guard - Remote CO2 w/ Dixell Controller

## Models

DP610RC.5741-A.6527



Features	Standard	Options
<b>EXTERIOR COLOR</b>	<input type="checkbox"/> Carbon Gray Cherry Veneer	
<b>BASE SUPPORT</b>	<input type="checkbox"/> Rail system for shims	
<b>END PANELS</b>	<input type="checkbox"/> Full end panel(s) (Carbon Gray Cherry Veneer)	<input type="checkbox"/> Stainless steel
<b>LOWER FRONT PANEL</b>	<input type="checkbox"/> Publix matte black	
<b>UPPER FRONT PANEL</b>	<input type="checkbox"/> Carbon Gray Cherry Veneer	
<b>UPPER REAR</b>	<input type="checkbox"/> Open upper rear	
<b>INTERIOR</b>	<input type="checkbox"/> Stainless steel	
<b>PAN COVERS</b>	<input type="checkbox"/> (15) 1/3 size pan covers & spoons	
<b>PANS</b>	<input type="checkbox"/> (9) 4"D & (9) 2.5"D 1/3 size pans w/ support rails	
<b>SIGN HOLDER</b>	<input type="checkbox"/> Top sign holder	
<b>SNEEZE GUARD</b>	<input type="checkbox"/> Clear lift-up sneeze guard glass w/ stainless steel posts	
<b>ELECTRICAL CONNECT</b>	<input type="checkbox"/> Leads	
<b>REFRIGERATION</b>	<input type="checkbox"/> Remote liquid CO2 refrigeration w/ Dixell controller	

## Applications

- One-sided Inline cold-well modular unit for self-service pans.
- Accommodates (15) 1/3 size pans.

# Olive Refrigerated 5-Pan Olive Unit Inline - Carbon Gray - Lift-up Sneeze Guard - Remote CO2 w/ Dixell Controller

Model	L x D x H (Lengths include end panels)
DP610RC.5741-A.6527	76"L x 39-1/2"D x 70-1/2"H

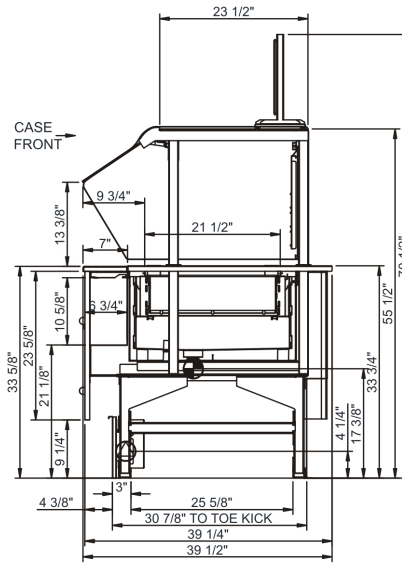

## IMPORTANT NOTES:

- 1) Units must be shimmed during installation to ensure the unit is level and plumb.
- 2) Refrigeration air flow above and below pans.



## WARNING

This product can expose you to chemicals including Urethane (Ethyl Carbamate), which are known to the State of California to cause cancer and birth defects or other reproductive harm. For more information go to [www.P65Warnings.ca.gov](http://www.P65Warnings.ca.gov).

## INTENDED ENVIRONMENT

Designed to operate in ambient conditions of 75°F with 55% relative humidity.

## WARMEST AVG PRODUCT TEMP

Zone	Temp (°F)
1	38

## INTENDED USE OF DISPLAY AREAS

Zone	Intended Use
1	Packaged / unpackaged refrigerated products