

Olive - Refrigerated 5-Pan Olive Unit Inline - Cherry - Lift-up Sneeze Guard - Remote CO2 w/ Dixell Controller

Models

DP610RC.5741.6527



Features	Standard	Options
EXTERIOR COLOR	<input type="checkbox"/> Cherry veneer	
BASE SUPPORT	<input type="checkbox"/> Rail system for shims	
END PANELS	<input type="checkbox"/> Full end panel(s) (Cherry veneer)	<input type="checkbox"/> Stainless steel
LOWER FRONT PANEL	<input type="checkbox"/> Publix matte black	
UPPER FRONT PANEL	<input type="checkbox"/> Cherry veneer	
UPPER REAR	<input type="checkbox"/> Open upper rear	
INTERIOR	<input type="checkbox"/> Stainless steel	
PAN COVERS	<input type="checkbox"/> (15) 1/3 size pan covers & spoons	
PANS	<input type="checkbox"/> (9) 4"D & (9) 2.5"D 1/3 size pans w/ support rails	
SIGN HOLDER	<input type="checkbox"/> Top sign holder	
SNEEZE GUARD	<input type="checkbox"/> Clear lift-up sneeze guard glass w/ stainless steel posts	
ELECTRICAL CONNECT	<input type="checkbox"/> Leads	
REFRIGERATION	<input type="checkbox"/> Remote liquid CO2 refrigeration w/ Dixell controller	

Applications

- One-sided Inline cold-well modular unit for self-service pans.
- Accommodates (15) 1/3 size pans.
- Models used in Olive & Prepared Foods.

Olive Refrigerated 5-Pan Olive Unit Inline - Cherry - Lift-up Sneeze Guard - Remote CO2 w/ Dixell Controller

Model	L x D x H (Lengths include end panels)
DP610RC.5741.6527*	76"L x 39-1/2"D x 70-1/2"H

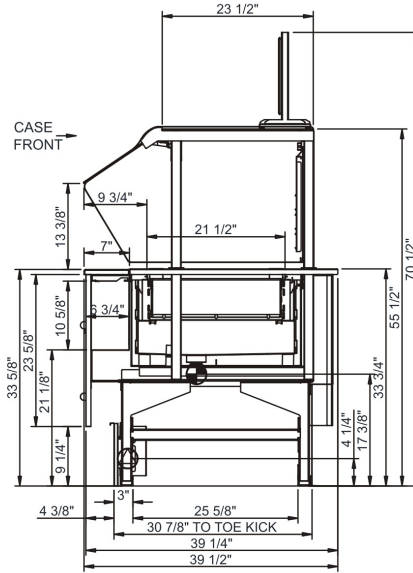

IMPORTANT NOTES:

- 1) Units must be shimmed during installation to ensure the unit is level and plumb.
- 2) Refrigeration air flow above and below pans.
- 3) Compressor air front intake, rear discharge.

WARNING

This product can expose you to chemicals including Urethane (Ethyl Carbamate), which are known to the State of California to cause cancer and birth defects or other reproductive harm. For more information go to www.P65Warnings.ca.gov.

INTENDED ENVIRONMENT

Designed to operate in ambient conditions of 75°F with 55% relative humidity.

WARMEST AVG PRODUCT TEMP

Zone	Temp (°F)
1	38

INTENDED USE OF DISPLAY AREAS

Zone	Intended Use
1	Packaged / unpackaged refrigerated products

* Additional lead-time required
 INFORMATION IS SUBJECT TO CHANGE WITHOUT NOTICE. Visit www.structuralconcepts.com for the most current specs.

