

Technical Information

Structural Concepts®

DELIVERING FRESH. ALWAYS.™

Grocerant - Refrigerated 5-Pan Olive Unit Inline - Cherry - Lift-up Sneeze Guard - Remote DX w/ Dixell Controller

DIMENSIONS / SHIPPING				
Model	L"	L1"	L2"	Est Wt (lbs)
DP610R.5741.6527	N/A	76.000	8.000	N/A
DP610R.5741-A.6527	N/A	76.000	8.000	N/A

ELECTRICAL															
Model	System Circuit Volts			Ph	Frq	Rated Load Amps	Min Cir Amps	Max OCP Amps	Watts	Wires	NEMA Plug	Amps Lights	Amps Fans	Amps Anti-Sweats	Amps Misc/Refrig/Heat
DP610R.5741.6527	Remote (DX)	Circuit #1	110-120	1	60	2.06	15	15	89	2+G	Leads Single	0.70	0.70	0.66	N/A
DP610R.5741-A.6527	Remote (DX)	Circuit #1	110-120	1	60	2.06	15	15	89	2+G	Leads Single	0.70	0.70	0.66	N/A

REFRIGERATION													
Model	Zone	Section	System	Envt	REMOTE REFRIGERATION					GLYCOL / R744 REFRIGERATION			
					SST (°F)	Conv. Rack BTUH	Para. Rack BTUH	Defrost Interval (Hrs)	Defrost Duration	Total GPM	Pressure Drop (psi)	Concent (%)	Liquid Temp (°F)
DP610R.5741.6527	All	Main	Remote-DX	Type I	20	1,987	1,840	4.00	30.00	N/A	N/A	N/A	N/A
DP610R.5741-A.6527	All	Main	Remote-DX	Type I	20	1,987	1,840	4.00	30.00	N/A	N/A	N/A	N/A

INTENDED ENVIRONMENT		
Type I - Designed to operate in ambient conditions of 75°F with 55% relative humidity unless noted otherwise under Envt above.		
WARMEST AVERAGE PRODUCT TEMP & INTENDED USE OF ZONES		
Zone	Temp (°F)	Intended Use
1	38	Packaged / unpackaged refrigerated products-Prechilled to Warmest Avg Prod Temp.

IMPORTANT NOTES
1) Units must be shimmed during installation to ensure the unit is level and plumb.
2) Refrigeration air flow above and below pans.
3) Compressor air front intake, rear discharge.

REGULATORY	
All Models	Accordance with AHRI Std 1200 ETL Listed to UL 471 ETL Listed to CAN/CSA 22.2 No. 120 ETL Sanitation to NSF/ANSI 7



In Accordance with
AHRI Std 1200

Technical Information

Grocerant - Refrigerated 5-Pan Olive Unit In-line - Cherry - Lift-up Sneeze Guard - Remote DX w/ Dixell Controller

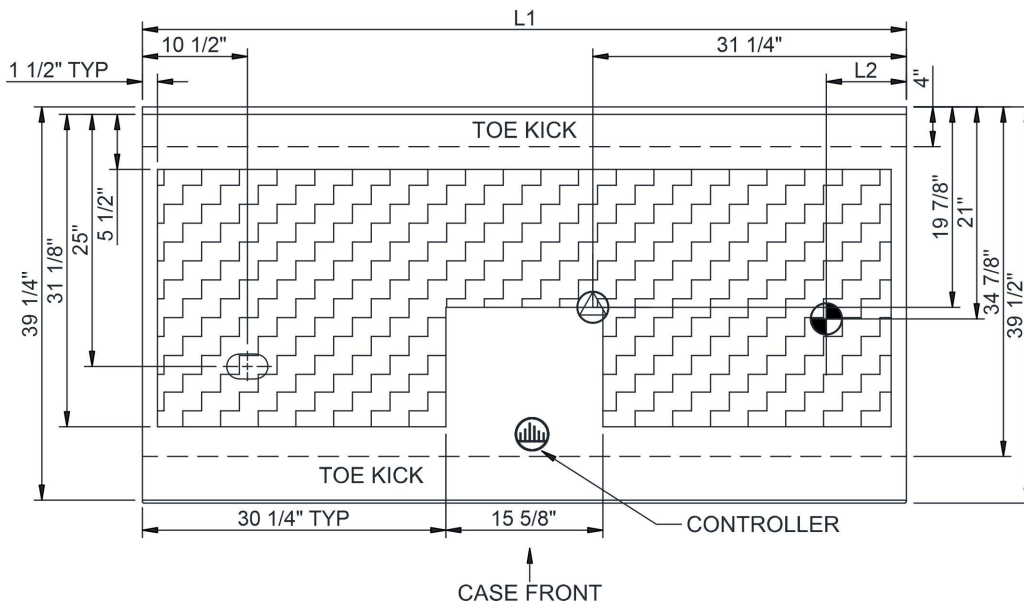
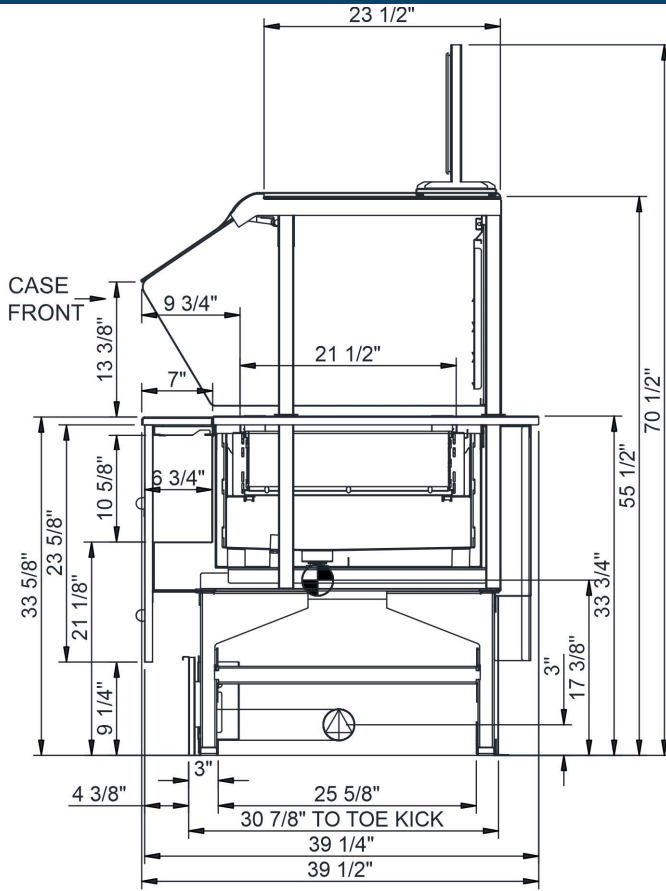

NOTE: ALL DIMENSIONS APPROXIMATE

- ⊕ ELECTRICAL JUNCTION BOX (SUPPLIED WITH 6" LEADS OR POWER CORD).
- ⊕ REFRIGERATION LINE CONNECTION.
- ⊕ SELF-CONTAINED CASE SERVICE ACCESS AREA.
- ⊖ LOCATION OF DRAIN TUBE FOR REMOTE REF. ONLY (SUPPLIED WITH 3/4" OR 1 1/2" PVC TUBE).
- ⊖ REMOTE FLOOR SINK & UTILITIES ACCESS AREA.
- ⊖ DRY CASE SERVICE ACCESS AREA.