

Technical Information

Grocerant - Sandwich Prep Case With Refrigerated Rear Storage - CO2 w/ Danfos Controller

Structural Concepts®

DELIVERING FRESH. ALWAYS.™

DIMENSIONS / SHIPPING				
Model	L"	L1"	L2"	Est Wt (lbs)
DP46RC.5718A.7716	46.500	48.000	4.625	N/A
DP58RC.5718A.7716	62.750	64.250	6.250	N/A
DP610RC.5718A.7716	76.000	77.500	6.375	N/A
DP812RC.5718A.7716	88.000	89.500	5.875	N/A
DP914RC.5718A.7716	101.000	102.500	16.375	N/A

ELECTRICAL														
Model	System Circuit Volts	Ph	Frq	Rated Load Amps	Min Cir Amps	Max OCP Amps	Watts	Wires	NEMA Plug	Amps Lights	Amps Fans	Amps Anti-Sweats	Amps Misc/Refrig/Heat	
DP46RC.5718A.7716	CONTACT FACTORY FOR UPDATED INFORMATION													
DP58RC.5718A.7716	Remote (R744 T)	Circuit #1	110-120	1	60	2.06	15	15	89	2+G	Leads Single	0.70	0.70	N/A
DP610RC.5718A.7716	Remote (R744 T)	Circuit #1	110-120	1	60	2.06	15	15	89	2+G	Leads Single	0.70	0.70	N/A
DP812RC.5718A.7716	CONTACT FACTORY FOR UPDATED INFORMATION													
DP914RC.5718A.7716	CONTACT FACTORY FOR UPDATED INFORMATION													

REFRIGERATION													
Model	Zone	Section	System	Envt	REMOTE REFRIGERATION					GLYCOL / R744 REFRIGERATION			
					SST (°F)	Conv. Rack BTUH	Para. Rack BTUH	Defrost Interval (Hrs)	Defrost Duration	Total GPM	Pressure Drop (psi)	Concent (%)	Liquid Temp (°F)
DP46RC.5718A.7716	CONTACT FACTORY FOR UPDATED INFORMATION												
DP58RC.5718A.7716	All	Main	Remote-R744 TRANSCRITICAL	Type I	20	1,685	1,560	4.00	30.00	N/A	N/A	N/A	N/A
DP610RC.5718A.7716	All	Main	Remote-R744 TRANSCRITICAL	Type I	20	1,987	1,840	4.00	30.00	N/A	N/A	N/A	N/A
DP812RC.5718A.7716	CONTACT FACTORY FOR UPDATED INFORMATION												
DP914RC.5718A.7716	CONTACT FACTORY FOR UPDATED INFORMATION												

INTENDED ENVIRONMENT		
Type I - Designed to operate in ambient conditions of 75°F with 55% relative humidity unless noted otherwise under Envt above.		
WARMEST AVERAGE PRODUCT TEMP & INTENDED USE OF ZONES		
Zone	Temp (°F)	Intended Use
1	38-40	Unpackaged refrigerated products-Prechilled to Warmest Avg Prod Temp.

IMPORTANT NOTES
1) Units must be shimmed during installation to ensure the unit is level and plumb.

REGULATORY	
All Models	Accordance with AHRI Std 1200 ETL Listed to UL 471 ETL Listed to CAN/CSA 22.2 No. 120 ETL Sanitation to NSF/ANSI 7



In Accordance with
AHRI Std 1200

Technical Information

Grocerant - Sandwich Prep Case With Refrigerated Rear Storage - CO2 w/ Danfos Controller

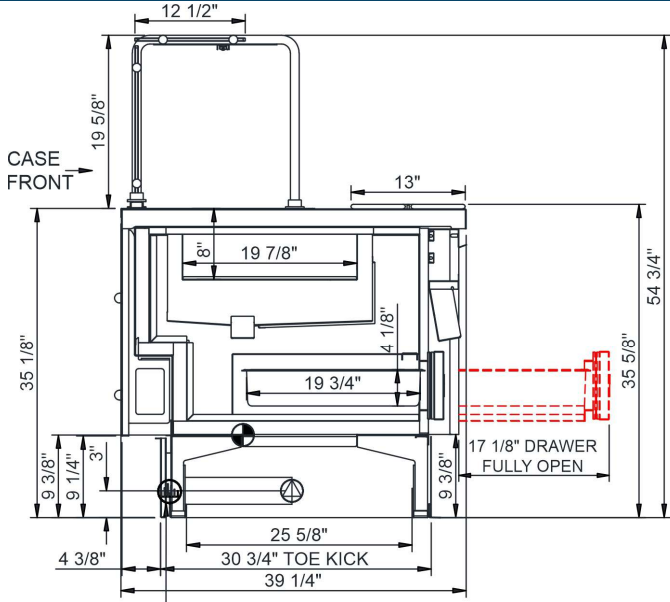

CONTROLLER: DP(L)R.5718A.6527,
DP(L)RC.5718A.6527, DP(L)RC.5718A.7716,
DP(L)R.5718A.7716

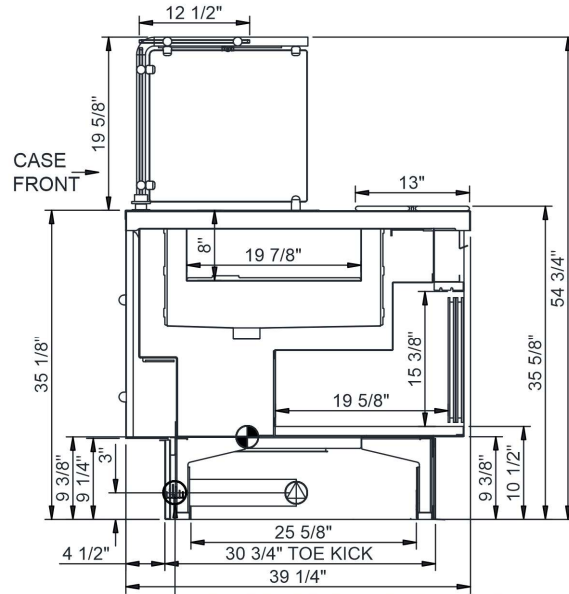

CONTROLLER: DP914R.5718A.6527,
DP914RC.5718A.6527, DP914RC.5718A.7716,
DP914R.5718A.7716

MODEL	w/ CONTROLLER
DP(L)R.5718A.7716	REMOTE DX w/ DANFOSS
DP(L)RC.5718A.7716	CO2 w/ DANFOSS
DP(L)R.5718A.6527	REMOTE DX w/ DIXELL
DP(L)RC.5718A.6527	CO2 w/ DIXELL
MODEL	w/o CONTROLLER
DP(L)52R.5718A	REMOTE DX
DP(L)52RG.5718A	REMOTE GLYCOL

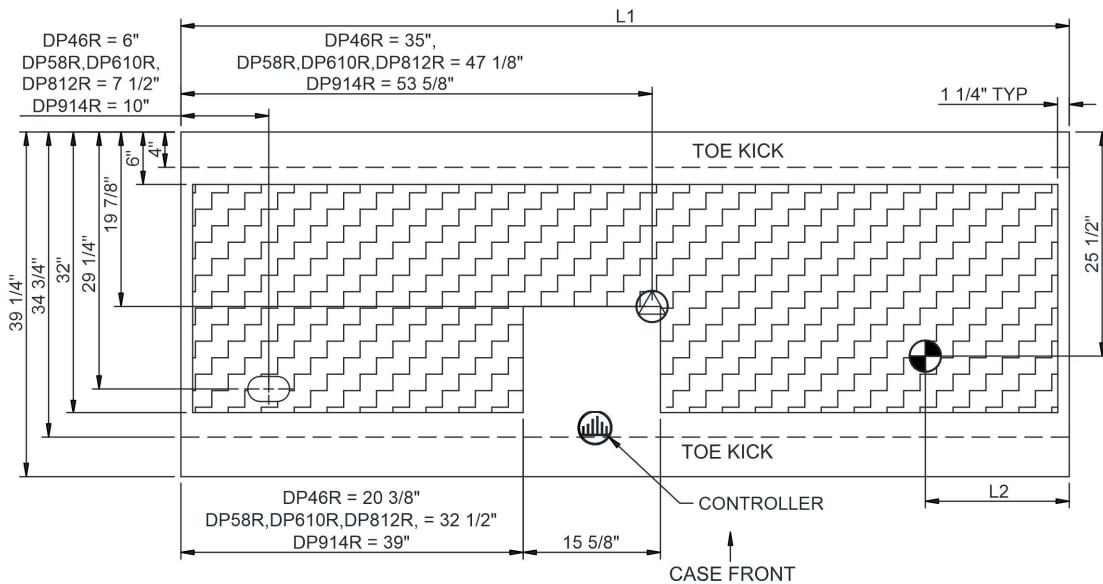

NOTE: ALL DIMENSIONS APPROXIMATE

⊗ ELECTRICAL JUNCTION BOX (SUPPLIED WITH 6" LEADS OR POWER CORD).
○ LOCATION OF DRAIN TUBE FOR REMOTE REF. ONLY (SUPPLIED WITH 3/4" OR 1 1/2" PVC TUBE).

⊕ REFRIGERATION LINE CONNECTION.
⊞ REMOTE FLOOR SINK & UTILITIES ACCESS AREA.

▨ SELF-CONTAINED CASE SERVICE ACCESS AREA.
▩ DRY CASE SERVICE ACCESS AREA.