

Oasis

26" Refrigerated Self-Service Pizza Dough Case

Structural Concepts®

DELIVERING FRESH. ALWAYS.™

• B24R.7981

26"L x 29"D x 54-1/4"H

Included

- LED lights



B24R.7981

Specify	Standard Features	Additional Options
EXTERIOR COLOR	• Laminated (specify color) (confirm pattern/grain direction)	
INTERIOR COLOR - LOWER	• Stainless steel	
INTERIOR COLOR - UPPER	• Painted (specify color)	
BASE	• Casters w/ levelers	
END PANELS	• Full end panels w/mirror interior	
FRONT TOE KICK	• Painted (specify color)	
PRICE TAG MOLDING	• Silver	
UPPER DISPLAY	• None	• Solid shelf, non-lighted
LIGHTS	• LED top & shelf lights	

Intended Environment: Type I - Designed to operate in ambient conditions of 75°F with 55% relative humidity unless noted otherwise in system information below.		
Zone	Intended Product To Be Displayed	Warmest Avg Prod Temp ° F
1	Packaged refrigerated products	40

PLAN VIEW

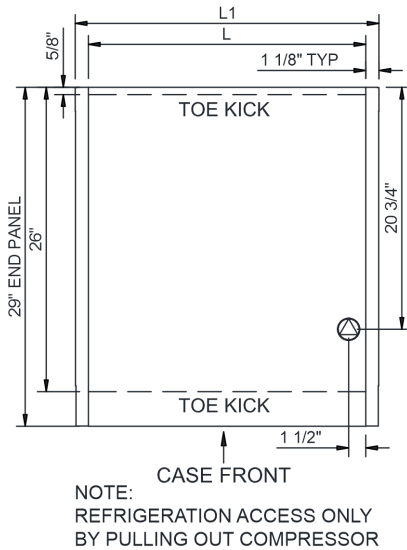

SIDE VIEW

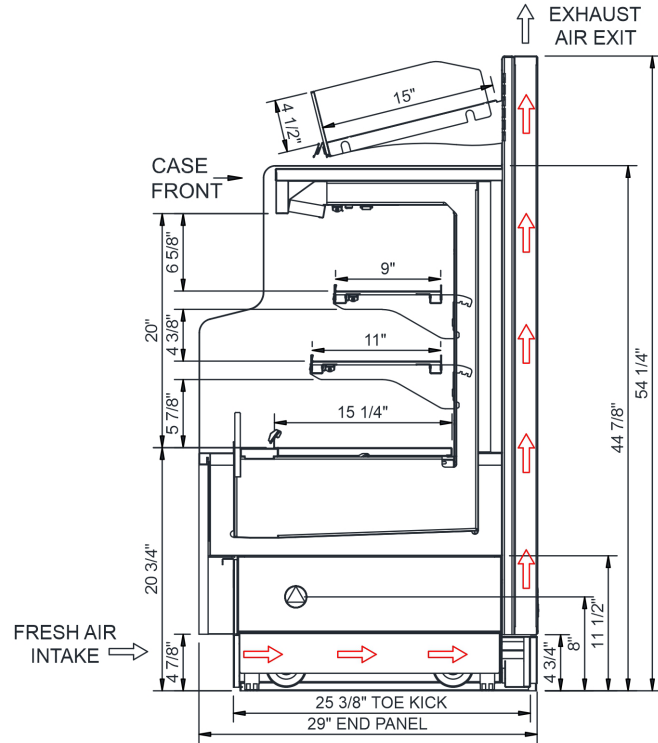

NOTE: ALL DIMENSIONS APPROXIMATE

- ELECTRICAL JUNCTION BOX (SUPPLIED WITH 6" LEADS OR POWER CORD).
- LOCATION OF DRAIN TUBE FOR REMOTE REF. ONLY (SUPPLIED WITH 3/4" OR 1 1/2" PVC TUBE).

- REFRIGERATION LINE CONNECTION.
- REMOTE FLOOR SINK & UTILITIES ACCESS AREA.

- SELF-CONTAINED CASE SERVICE ACCESS AREA.
- DRY CASE SERVICE ACCESS AREA.

Model Technical Specifications																
Model	L"	L1"	L2"	System	Circuit	Volts	Phs	Freq	Amps ***	Watts	Wires	NEMA Plug	SST	Conv. Rack BTUH	Para. Rack BTUH	Est Wt
B24R.7981	23.75	26.00	.00	Self-Contained (R290)	Circuit #1	110-120	1	60	10.85	973	2+G	5-15P or L5-15P	N/A	N/A	N/A	N/A

*** Does not include electric defrost on freezer models.

Regulatory Approvals:

All Models
 Accordance with AHRI Std 1200
 ETL Listed to UL 471 & UL 60335-2-89
 ETL Listed to CAN/CSA 22.2 No. 120
 ETL Sanitation to NSF/ANSI 7



Important Notes:

- 1) Performance issues (product temperatures, water on floor, etc.) caused by adverse conditions are not covered by warranty.
- 2) Levelers must be adjusted during installation to ensure unit is level and plumb.
- 3) Keep unit at least 15' from exterior doors, overhead HVAC vents, or any air curtain disruption.
- 4) Do not expose unit to direct sunlight or any heat source (ovens, fryers, etc.).
- 5) End panels must be tightly joined or kept at least 6" away from any structure to prevent condensation.
- 6) Tile floors, low ceilings, or small rooms will increase noise level.
- 7) Compressor air intake at lower front, discharge from lower rear. Lower panels cannot be blocked. Wall spacers required for proper air flow.
- 8) If GFCI is required, a GFCI breaker MUST be used in lieu of a GFCI receptacle.

⚠ WARNING: This product can expose you to chemicals, including Urethane (Ethyl Carbamate), which are known to the State of California to cause cancer and birth defects or other reproductive harm. For more information go to www.P65Warnings.ca.gov.