

# Technical Information

Oasis - 26" Refrigerated Self-Service Pizza Dough Case

Structural Concepts®

DELIVERING FRESH. ALWAYS.™

DIMENSIONS / SHIPPING				
Model	L"	L1"	L2"	Est Wt (lbs)
B24R.7981	23.750	26.000	0.000	N/A

ELECTRICAL															
Model	System Circuit Volts			Ph	Frq	Rated Load Amps	Min Cir Amps	Max OCP Amps	Watts	Wires	NEMA Plug	Amps Lights	Amps Fans	Amps Anti-Sweats	Amps Misc/Refrig/Heat
B24R.7981	Self-Contained (R290)	Circuit #1	110-120	1	60	10.85	15	15	969	2+G	5-15P or L5-15P	N/A	0.45	4.08	6.32

REFRIGERATION														
Model	Zone	Section	System	Env't	REMOTE REFRIGERATION					GLYCOL / R744 REFRIGERATION				
					SST (°F)	Conv. Rack BTUH	Para. Rack BTUH	Defrost Interval (Hrs)	Defrost Duration	Total GPM	Pressure Drop (psi)	Concent (%)	Liquid Temp (°F)	
B24R.7981	All	Refrigerator	Self-Contained-R290	Type I	N/A	N/A	N/A	N/A	N/A	N/A	N/A	N/A	N/A	N/A

INTENDED ENVIRONMENT	
Type I - Designed to operate in ambient conditions of 75°F with 55% relative humidity unless noted otherwise under Env't above.	

WARMEST AVERAGE PRODUCT TEMP & INTENDED USE OF ZONES		
Zone	Temp (°F)	Intended Use
1	40	Packaged refrigerated products-Prechilled to Warmest Avg Prod Temp.

- | IMPORTANT NOTES  |
|--|
| <ol style="list-style-type: none"> <li>1) Performance issues (product temperatures, water on floor, etc.) caused by adverse conditions are not covered by warranty.</li> <li>2) Levelers must be adjusted during installation to ensure unit is level and plumb.</li> <li>3) Keep unit at least 15' from exterior doors, overhead HVAC vents, or any air curtain disruption.</li> <li>4) Do not expose unit to direct sunlight or any heat source (ovens, fryers, etc.).</li> <li>5) End panels must be tightly joined or kept at least 6" away from any structure to prevent condensation.</li> <li>6) Tile floors, low ceilings, or small rooms will increase noise level.</li> <li>7) Compressor air intake at lower front, discharge from lower rear. Lower panels cannot be blocked. Wall spacers required for proper air flow.</li> <li>8) If GFCI is required, a GFCI breaker MUST be used in lieu of a GFCI receptacle.</li> </ol> |

REGULATORY	
All Models	Accordance with AHRI Std 1200 ETL Listed to UL 471 & UL 60335-2-89 ETL Sanitation to NSF/ANSI 7



In Accordance with  
**AHRI Std 1200**

# Technical Information

Oasis - 26" Refrigerated Self-Service Pizza Dough Case

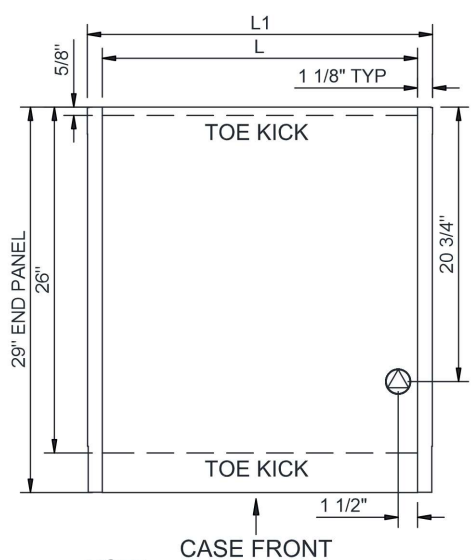
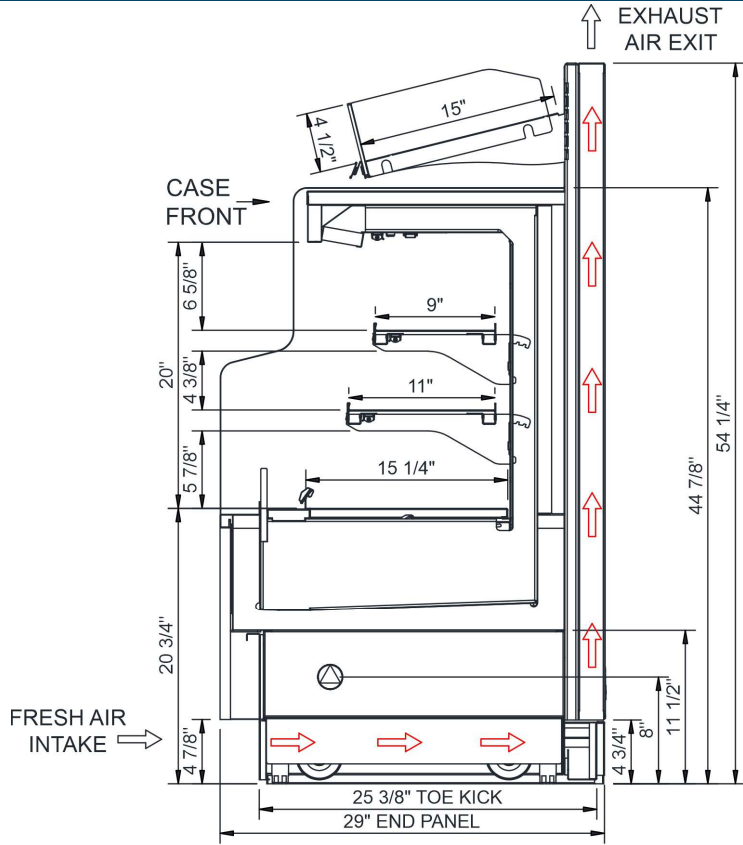

NOTE:  
REFRIGERATION ACCESS ONLY  
BY PULLING OUT COMPRESSOR

NOTE: ALL DIMENSIONS APPROXIMATE

- ⊗ ELECTRICAL JUNCTION BOX (SUPPLIED WITH 6" LEADS OR POWER CORD).
- ⊕ REFRIGERATION LINE CONNECTION.
- ⊗ SELF-CONTAINED CASE SERVICE ACCESS AREA.
- ⊙ LOCATION OF DRAIN TUBE FOR REMOTE REF. ONLY (SUPPLIED WITH 3/4" OR 1 1/2" PVC TUBE).
- ⊕ REMOTE FLOOR SINK & UTILITIES ACCESS AREA.
- ⊗ DRY CASE SERVICE ACCESS AREA.